

TC 9-56

DEPARTMENT OF THE ARMY TRAINING CIRCULAR

SKS RIFLE
SIMONOV TYPE 56

HEADQUARTERS, DEPARTMENT OF THE ARMY
OCTOBER 1969

THE 7.62-MM SIMONOV SEMIAUTOMATIC CARBINE (SKS)

General

The Soviet-designed Simonov semiautomatic carbine (fig 1), a gas-operated, integral box magazine-fed weapon equipped with a folding blade bayonet, is now obsolete in the Soviet Army, but is used by most of the other Eurasian Communist countries. This weapon has been manufactured in East Germany as the Karabiner-S (fig 2), in the People's Republic of China as the Type 56 semiautomatic carbine, in North Korea as the Type 63 carbine, and in Yugoslavia as the M59/66 rifle. The country of origin can be determined by the markings. The Soviet and East German weapons usually carry the year of manufacture and the serial number on the front left of the receiver; the PRC weapons have the symbol 五六式 (Type 56) located there, and the late PRC Type 56 has a spike bayonet. The North Korean weapons have "63" stamped into the receiver cover. The East German version has a hole through the stock for attaching the lower end of the sling; the others all have sling swivels. The Yugoslav M59/66 (fig 3) has a prominent spigot-type grenade launcher permanently attached to the muzzle and a folding grenade launching sight (fig 4) at the rear of the launcher.

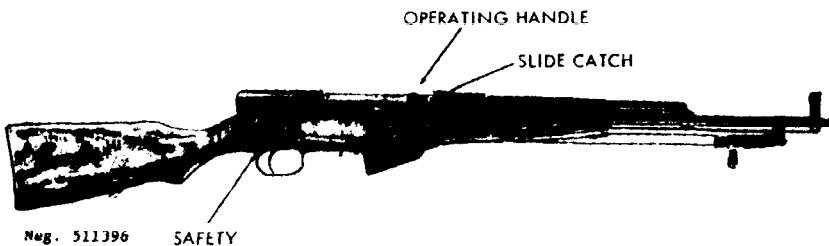

Figure 1 . Soviet Simonov semiautomatic carbine (SKS).

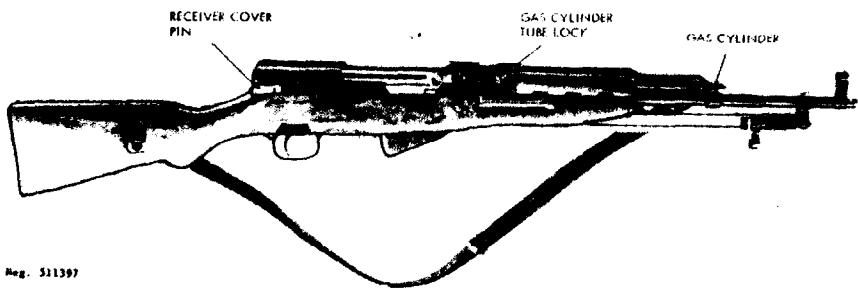

Fig. 511397

Figure 2 . East German Karabiner-S.

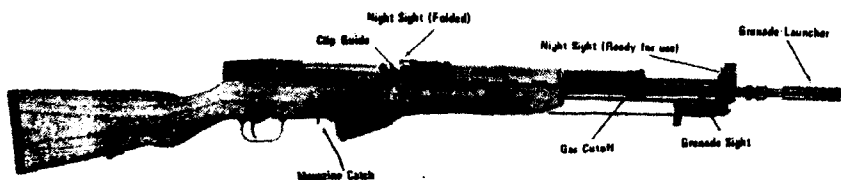

Fig. 511398

Figure 3 . Yugoslav M59/66 rifle.

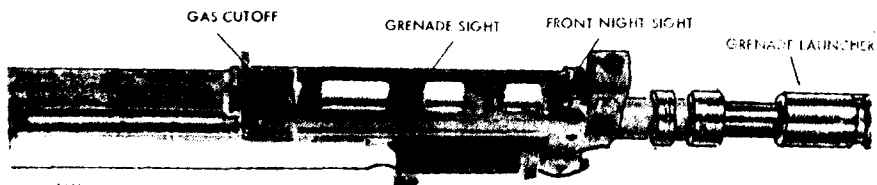

Fig. 511399

596248-111139

Figure 4 . M59/66 gas cutoff.

Technical Data

Technical data concerning the SKS carbine will be found in table II.

Operation

a. Grasp the operating handle (fig 1), pull it fully to the rear, and release it. If the magazine is empty, the bolt will remain open. Insert a stripper clip into the clip guides at the top front of the bolt carrier, and with the thumb as close as possible to the base of the top cartridge, press the cartridges off the clip and into the magazine (fig 5). Remove the empty clip. If clipped

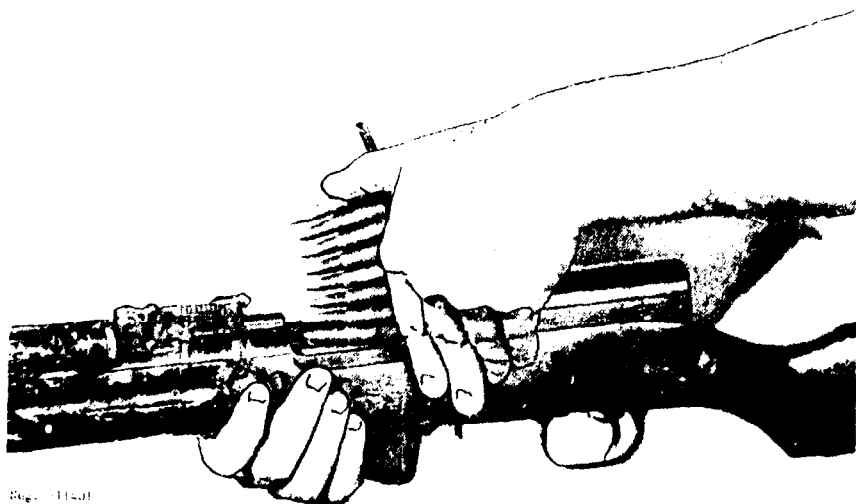

Figure 5 . Loading the SKS.

ammunition is not available, individual cartridges can be placed on top of the magazine follower and pressed down into the magazine until it is full. Pull operating handle rearward and release it; the bolt will run forward and chamber a cartridge.

CAUTION: The rifle is now ready to fire!

b. If the rifle is not to be fired immediately, apply the safety (fig 1) by rotating it forward and upward.

c. Set the rear sight for the desired range by depressing the slide catch (fig 1) and moving the sight bar along the leaf until the front edge of the bar is aligned with the line below the number that corresponds to the range in hundreds of meters. The first character on the sight leaf is a battle sight setting that is used in combat, for shooting at ranges up to 300 meters. The Yugoslav M59/66 has fold-down luminous sights (fig 3) for use when firing under poor light conditions; flip these up for use.

d. The front sight is adjustable for zero.

e. To fire the weapon, rotate the safety rearward until it is parallel to the trigger; then aim, using a normal sight picture, and press the trigger. The SKS will fire one shot and reload itself; when the last round has been fired, the bolt will remain open. (The gas cutoff of the Yugoslav M59/66 must be turned to the right for the rifle to function. Press the gas cutoff button (fig 4) down and swing to the right).

f. To unload or clear the SKS, apply the safety, then pull back the magazine catch (fig 3) and allow the magazine to swing open. Remove all cartridges and close the magazine. Grasp the operating handle, pull it fully rearward to eject any cartridge that might have been in the chamber, and release the handle; the bolt will remain open. Inspect to insure that no cartridges remain in the magazine, barrel, or receiver. Close the bolt, either by opening the magazine again and pulling rearward on the operating handle and releasing it, or by pressing the magazine platform down slightly and pulling the operating handle rearward and releasing it. Move the safety to the ready position, press the trigger and apply the safety.

g. The SKS bayonet is affixed by forcing the hilt to the rear (against spring pressure) and swinging the bayonet forward until it locks to the muzzle. This action is reversed to fold the bayonet in its stowed position.

h. The Yugoslav M49/56 can launch rifle grenades. The grenades must have tail booms of 22-mm inside diameter and if at all possible, only Yugoslav-made grenades should be launched. Prior to firing grenades, clear the rifle and cut off the gas mechanism by pressing in the lock (fig 4) and rotating it to the top of the gas cylinder. Lift the grenade sight to its vertical position. Pull the operating handle rearward until it is caught open and insert a grenade launching cartridge into the chamber. (Note: These cartridges are packed in the tail booms of the Yugoslav grenades.) Under no circumstances can a bulletted cartridge be used; to do so will cause the grenade to explode on the launcher. Depress the follower and while holding it down pull the operating handle rearward then ease it forward. Tap the operating handle forward to insure that the bolt locked. Slide the appropriate type grenade fully onto the launcher. To launch the grenade, move the safety to the fire position, align the appropriate range arc (fig 6) with the ogive (largest diameter) of the grenade and then align the sight and grenade on the target. Press the trigger.

i. Prior to firing successive rounds, the operating handle must be smartly drawn rearward to eject the fired cartridge case. Prior to firing bulletted rounds, fold the grenade sight rearward, press in the lock (fig 6) and rotate it to the right as far as possible.

Disassembly and Assembly

a. To disassemble the SKS carbine:

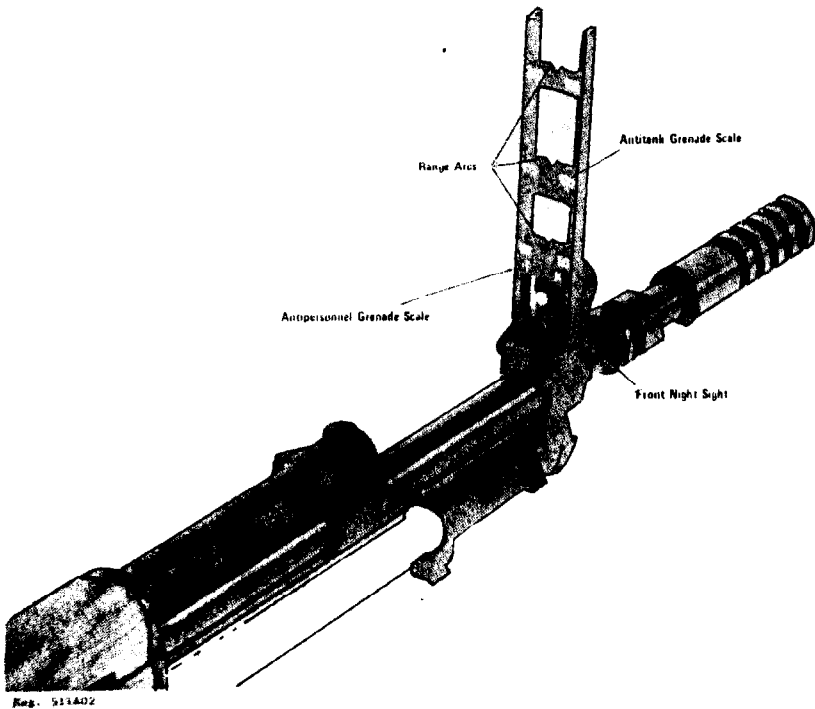

Figure 6 M59/66 grenade sight erected.

(1) Clear the weapon

(2) Press in on the cover in the butt plate until the combination tool case is ejected. Unlock the bayonet, let it hang vertically, and after disengaging the head of the cleaning rod from the front sight base, pull the cleaning rod out of the rifle.

Note: The East German Karabiner-S does not have a combination tool case in the butt, nor does it have a cleaning rod; these are carried separately.

(3) Rotate the receiver cover pin (fig 2) to a vertical position and pull it out as far as possible.

Note: It may be necessary to pry the receiver cover pin handle away from the receiver before it can be rotated.

Remove the receiver cover to the rear and pull the driving spring assembly out of the bolt carrier.

(4) Open the magazine by pulling the magazine catch (fig 3) to the rear. Pull the operating handle fully rearward, and lift the bolt carrier and bolt out of the receiver. Separate the bolt from the bolt carrier.

(5) Rotate the gas cylinder tube lock (fig 2) to its uppermost position and lift the rear of the handguard to remove the gas cylinder tube and the gas piston. The tube can be upended and the piston will slide out.

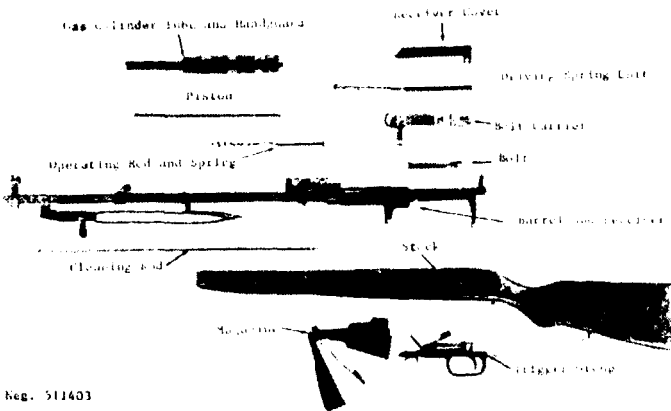

Figure 7 . SKS field stripped.

(6) If necessary, the trigger group can be removed by depressing the catch located behind the loop of the trigger guard and pulling the trigger group down and out of the rifle. The safety must be in the safe position before the catch can be depressed.

(7) No further disassembly is necessary or desirable.

b. To reassemble the weapon, follow the procedure listed below:

(1) Invert the rifle and engage the pins at the front of the trigger group with the notches behind the magazine box. Swing the trigger group into position in the stock and seat it by a blow of the hand on the loop of the trigger guard. Move the safety to the fire position to insure that the catch is fully engaged.

(2) Slide the gas piston, small end first, into the gas cylinder tube; fit the large end of the tube over the gas cylinder (fig 2). Swing the rear end of the gas cylinder tube into the rear sight base and turn the gas cylinder lock downward.

(3) Place the bolt into the receiver, with the extractor to the right front, and position the rear of the bolt about three-eighths of an inch from the inner rear wall of the receiver. Lay the bolt carrier on the bolt and while pressing down on the carrier, move it slightly back and forth until it mates with the bolt. Slide the bolt and bolt carrier fully forward in the receiver. Insert the driving spring assembly, stepped end first, into the bolt carrier.

(4) Insure that the receiver cover pin is pulled fully out to the right, then slide the receiver cover into place from the rear. Secure it with the receiver cover pin and rotate the pin down to the locked position. Close the magazine, and replace the cleaning rod and the combination tool case.

Functioning

a. The SKS semiautomatic carbine is gas operated (fig 8). After the SKS has been loaded, pressure on the trigger releases the hammer, which impacts against the firing pin, firing the rifle. The propellant gases drive the bullet through the barrel,

and after the bullet passes the gas port, some of the gases are tapped off and directed against the piston head.

b. The propellant gases drive the piston and operating rod rearward against the bolt carrier. This forces the carrier and the hammer rearward and compresses the driving and hammer springs. After the bolt carrier moves rearward about one-fourth inch, a cam on the inner top of the bolt carrier (6, fig 8) contacts a projection on the top rear of the bolt and lifts the rear of the bolt up and out of its seat in the receiver. The disconnecter, which has been held down by the bolt, now rises. The bolt and bolt carrier now travel rearward as a unit, while the piston is returned forward by the spring. The extractor withdraws the fired cartridge case from the chamber and holds it to the bolt until the case strikes the fixed ejector and is expelled. The rear end of the bolt carrier strikes the inner wall of the receiver, and all rearward movement then terminates.

c. The driving spring expands and forces the bolt and bolt carrier forward; the bolt drives the top round out of the magazine and into the chamber. When the cartridge is fully seated in the chamber, the extractor snaps into the groove of the cartridge, and forward movement of the bolt ceases. The bolt carrier still has a short distance to travel, and as it does, cams the rear of the bolt down into its seat in the receiver; the bolt, as it seats, forces the disconnecter down. All forward movement terminates when the bolt carrier strikes the receiver.

d. The SKS has a complicated trigger mechanism (fig 9). The hammer is cocked by the recoiling bolt and is held cocked by a sliding sear. The sear is disengaged from the hammer by a spring-loaded trigger bar pivoted to the top of the trigger. The vertical alignment of the trigger bar is controlled by the disconnecter; this, when depressed by the locking of the bolt,

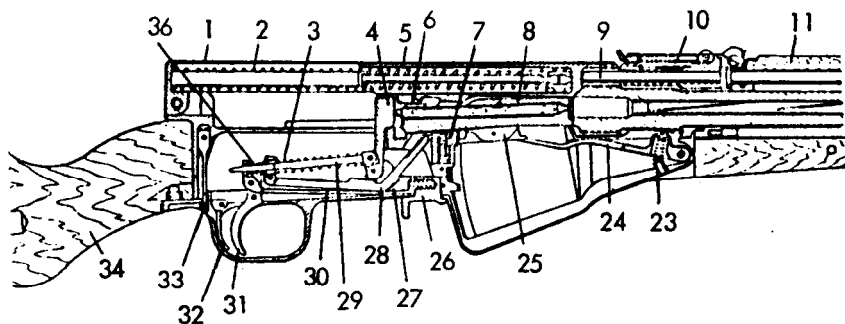

- | | |
|-------------------------|--------------------------|
| 1 BOLT COVER | 24 FOLLOWER ARM |
| 2 DRIVING SPRING | 25 FOLLOWER |
| 3 HAMMER SPRING | 26 MAGAZINE CATCH |
| 4 HAMMER | 27 SEAR |
| 5 BOLT CARRIER | 28 DISCONNECTOR |
| 6 LOCKING CAM | 29 HAMMER SPRING PLUNGER |
| 7 LAST ROUND STOP | 30 TRIGGER BAR |
| 8 BOLT | 31 TRIGGER |
| 9 TAPPET | 32 SAFETY |
| 10 TAPPET RETURN SPRING | 33 LATCH |
| 11 HANDGUARD | 34 STOCK |
| 23 FOLLOWER SPRING | 36 DISCONNECTOR SPRING |
- Neg. 511404

Figure 8 . SKS section.

presses down on the trigger bar and thus aligns the trigger bar and sear. Pressure on the trigger will force the trigger bar to move forward and disengage the sear from the hammer. The hammer swings forward to fire the rifle (A, fig 9), and as it does, a cam on the bottom of the hammer depresses the disconnecter, which in turn depresses the trigger bar below the sear. The sear spring forces the sear back against the hammer.

e. When the hammer is rocked back by the bolt, it strikes the disconnecter and depresses it. The disconnecter insures that the contact between the trigger bar and the sear is broken by depressing the trigger bar (B, fig 9). When the bolt

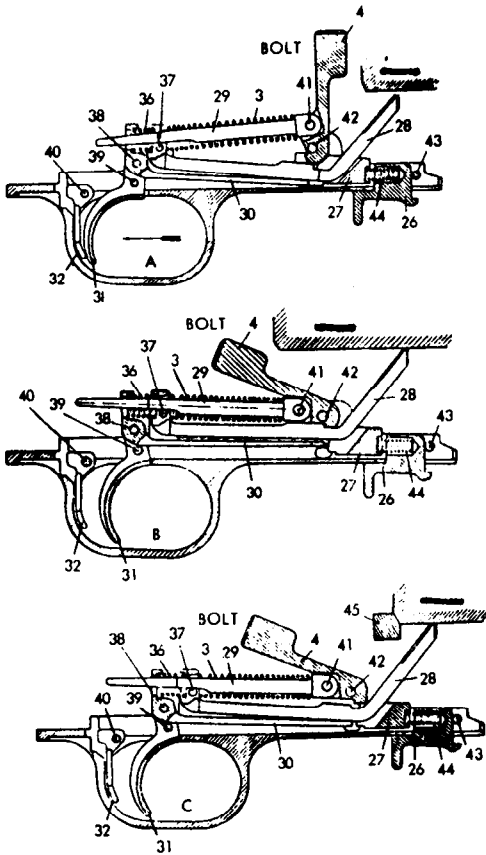

- 3 HAMMER SPRING
- 4 HAMMER
- 26 MAGAZINE CATCH
- 27 SEAR
- 28 DISCONNECTOR
- 29 HAMMER SPRING PLUNGER
- 30 TRIGGER BAR
- 31 TRIGGER
- 32 SAFETY
- 36 DISCONNECTOR SPRING
- 37 DISCONNECTOR PIN
- 38 TRIGGER BAR PIN
- 39 TRIGGER PIN
- 40 SAFETY PIVOT
- 41 HAMMER SPRING PLUNGER PIN
- 42 HAMMER PIN
- 43 MAGAZINE CATCH STOP PIN
- 44 SEAR SPRING
- 45 LOCKING SHOULDER

Neg. 511405

Figure 9 . SKS trigger mechanism.

counterrecoils, the hammer moves forward slightly, off the disconnecter, which rises and allows the trigger bar to rise against the bottom of the sear (the disconnecter having risen to its highest point). When the trigger is released, the trigger bar moves rearward until it is clear of the sear, then it springs up (if the bolt is locked) against the disconnecter, and the rifle is ready for another shot (C, fig 9).

f. The disconnecter (B, fig 9) prevents the rifle from firing if the bolt is not fully locked. It does this in two ways: by its control of the position of the trigger bar; and by a notch in the disconnecter, which intercepts the sear notch of the hammer if the disconnecter is not fully depressed, such as when the bolt is not fully locked.

g. The safety, when rotated up to the safe position, places a block behind the trigger and prevents the trigger from being pressed.

h. The bolt catch is normally held depressed by a light spring. When the last round is fed from the magazine, a nib on the magazine platform contacts the catch and forces it upward. As the recoiling bolt passes the catch, the catch protrudes into the bolt path and holds the bolt open.

Accessories

a. The following accessories are available for use with the SKS semiautomatic carbine:

(1) Combination tool kit.

(2) Sling.

(3) Charger clips.

(4) Standard Soviet pattern two-compartment oil and cleaning solvent container, or Yugoslav one-compartment oiler.

b. The combination tool kit, except for its cap, is similar in appearance and use to the kit for the AK-47 assault rifle. When

used as a cleaning rod guide, the cap is twisted into engagement with the front sight base.

c. The stripper clips are used to charge the rifle's magazine. Each holds 10 cartridges.

Table I. Rifle Malfunctions

Condition	Cause	Remedy
Fails to fire (cartridge in chamber)	Defective cartridge Bolt not fully locked	Reload Clean and lubricate
Fails to fire (no cartridge in chamber)	Short recoil	Clean and lubricate
Fails to extract or eject	Fouled weapon	Clean and lubricate

Table II. Rifle Technical Data

Weapon	Simonov carbine
Short name	SKS
Caliber (mm)	7.62
Length (mm)	1020
Mass, empty (kg)	3.85
Barrel length (mm)	520
Magazine capacity (rd)	10
Operation	Gas
Lock feature	Tilting bolt
Muzzle velocity (m/s)	735
Practical range (m)	400
Rate of fire (rd/min)	35-40
Method of loading	10-rd charger

I. PURPOSE AND SCOPE

This manual will provide information to the user which will allow proficiency training in the use and care of the Simonov Type 45, or the PRC Type 56 rifles. The information contained within this report will apply to either type rifle and where differences occur you will find notation to that effect.

II. CONDITIONS OF PERFORMANCE

You will be given a Simonov type rifle, ten rounds of 7.62X39MM ammunition, an inert round, a stripper clip, and a combination tool kit.

III. STANDARDS

Within the limitations given in performance standards below, adjust, load, fire, reduce a stoppage, unload, and clear the weapon.

IV. PERFORMANCE

- A. Adjust, load and fire the weapon. (See fig. 1.)

=====

FIGURE 1



- =====
1. Adjust:

- a. Adjust rear sight: (See fig. 2.)

1. Depress slide catch.
2. Slide sight carrier along the leaf until front edge of bar aligns with line below the number that corresponds to specified range in hundreds of meters (100-10000).

b. Adjust rear sight: (See fig. 2.)

FIGURE 2



1. Slip combination wrench over the front sight post. Turn post clockwise to raise the strike of the bullet; turn conterclockwise to lower the strike of bullet.
2. Remove tool from sight post.
2. Load within 20 seconds:
 - a. Rotate safety forward into the "safe" position this will be parallel with the stock.
 - b. Pull operating handle back and release it. If the magazine is empty, the bolt will remain open.
 - c. Insert a stripper clip into the clip guides at the front of the bolt carrier.
 - d. Press cartridges off the clip and into the magazine, (the thumb should be as close to the face of the clip as possible).
 - e. Remove empty clip.

NOTE: IF CLIPPED AMMO IS NOT AVAILABLE, INDIVIDUAL ROUNDS MAY BE PLACED ON TOP OF THE MAGAZINE FOLLOWER AND PRESSED DOWN INTO THE MAGAZINE UNTIL IT IS FULL.

- f. Pull operating handle back and release it.
(Bolt will go forward and chamber a round).
3. Fire within 5 seconds: ,
- a. Rotate the safety selector to the rear until it is pointed full down and is against the rear of the trigger guard. ("FIRE" position).
 - b. Aim and fire. The bolt will remain closed between rounds and open after the last round.
4. IMMEDIATE ACTION TO: Reduce stoppage.
- a. When rifle fails to fire, pull the operating handle back to eject bad round, watch for ejection, release handle to chamber new round.
 - b. Aim and attempt to fire.
 - c. If immediate action fails to reduce stoppage, unload, clear, disassemble, and inspect. Repair or replace defect and reassemble.
5. UNLOAD AND CLEAR WEAPON:
- a. Place weapon on "SAFE".
 - b. Pull back magazine catch and allow magazine to swing open.
 - c. Remove all cartridges.
 - d. Close the magazine.
 - e. Pull operating handle to the rear to eject any remaining rounds.
 - f. Release the handle (bolt will remain open).
 - g. Inspect to insure no cartridges remain in the magazine, chamber, or receiver.
 - h. Close bolt:
 - 1. Open magazine again and pull operating handle to rear and release.
 - 2. Pull operating handle to the rear, press down on the magazine follower slightly, then ease bolt carrier forward.

- i. Move safety to "FIRE" position.
 - j. Press trigger.
 - k. Place weapon on "SAFE".
- =====
- =====

MAINTAINING THE SKS RIFLE

V. PURPOSE

You will learn disassembly, cleaning, reassembly of the weapon within 35 minutes. You will also learn ammunition maintenance and to perform a function check.

VI. CONDITION OF PERFORMANCE

You will be given an SKS rifle, a cleaning rod and combination tool kit, 10 rounds of 7.62 X 39MM ammunition, a wire bore brush, chamber brush, and toothbrush, rifle bore cleaner, lube oil, solvent, cleaning patches, and clean rags.

VII. PERFORMANCE

A. Disassemble weapon within 2 minutes.

FIGURE 3.

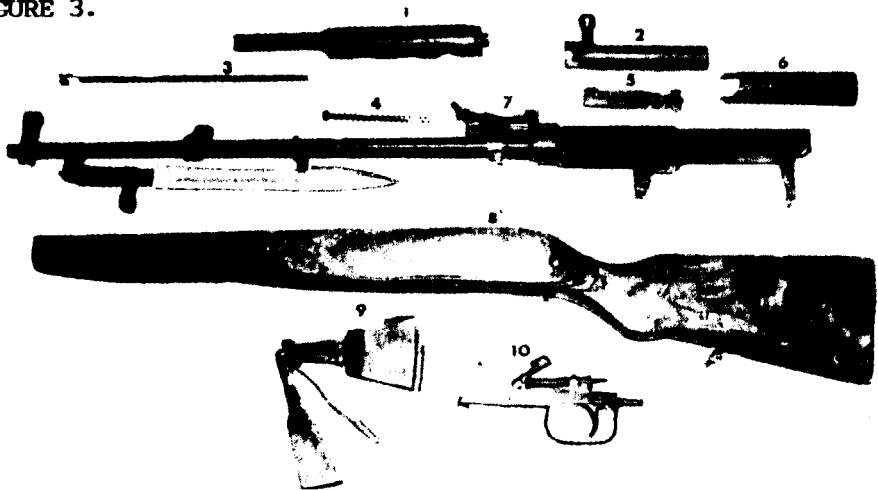

Rifle SKS Soviet

- | | |
|----------------------------------|----------------------|
| 1. Gas cylinder | 6. Receiver cover |
| 2. Bolt carrier | 7. Barrel & receiver |
| 3. Gas piston | 8. Stock |
| 4. Gas piston extension & spring | 9. Magazine |
| 5. Bolt | 10. Trigger group |

1. Insure weapon is clear and on "SAFE".
2. Remove recoil spring assembly:
 - a. Rotate the receiver cover retaining pin to the vertical position and pull to the right.
 - b. Remove the receiver cover by sliding it to the rear and lifting off.
 - c. Pull the recoil spring assembly from the bolt carrier.
3. Remove the bolt and carrier.
 - a. Pull operating handle to the rear.
 - b. Lift the bolt and bolt carrier out of the receiver.
4. Separate the bolt from the carrier.
5. Remove the gas cylinder and piston:
 - a. Rotate the gas cylinder tube lock until the handle is at a 45 degree angle to the rear.
 - b. Lift the rear of the handguard to remove the gas cylinder tube and gas piston.
 - c. Lower front end of tube and allow piston to slide out.
6. Remove gas piston extension and spring:
 - a. Place thumb in front of rear sight base.
 - b. Rotate gas cylinder tube lock slowly forward.
 - c. Remove and separate piston extension and spring.
7. Remove trigger group:
 - a. Insure weapon is on "SAFE".
 - b. Push in on trigger group retaining lock.
 - c. Pull trigger group up and out.

- d. Remove magazine by pulling up and out.
 - e. Unlock bayonet and separate barrel from the stock.
- B. Identify weapon parts. (See fig 2).
- C. Cleaning and maintainance. (See page 22).
- D. Reassemble weapon within 4 minutes:
- 1. Attach barrel to stock, and lock bayonet into closed position.
 - 2. Replace magazine into stock leaving it open.
 - 3. Replace trigger group:
 - a. Invert rifle and engage pins at the front of the trigger group (notches must be behind the magazine box).
 - b. Swing trigger group into position in the stock (seat it by a hand blow on the loop of the trigger guard).
 - c. Move safety to "FIRE" position to insure catch is fully engaged.
 - 4. Replace gas piston extension and spring:
 - a. Place gas piston extension and spring:
 - b. Hold gas tube lock in vertical position.
 - c. Insert gas piston extension with spring back into it's recess in front of the rear sight.
 - d. Push back into recess until it can be locked into place.
 - e. Lock by rotating gas tube lock 45 degree angle to the rear.
 - 5. Replace gas cylinder tube and piston:
 - a. Slide gas piston, small end first, into the front of the gas tube.

- b. Fit large end of gas tube over the gas cylinder block on barrel.
 - c. Swing rear end of gas cylinder tube into rear sight base.
 - d. Turn gas cylinder lock down into the detent.
6. Replace bolt and carrier:
- a. Connect bolt and carrier together and place bolt and carrier into the receiver.
 - b. Push down and forward all the way to seat.
7. Replace recoil spring assembly:
- a. Insert recoil spring assembly, curled end first, into bolt carrier.
 - b. Pull receiver cover pin fully to the right.
 - c. Slide receiver cover into place from the rear.
 - d. Secure cover with receiver cover pin.
 - e. Rotate pin down to locked position.
8. Close magazine.

VII. PERFORM FUNCTION CHECK WITHIN 20 SECONDS.

- 1. Pull operating handle to the rear and hold it.
- 2. Press down on magazine follower.
- 3. Allow bolt to go forward.
- 4. Place safety lever on "SAFE".
- 5. Press trigger (hammer should not go forward).
- 6. Place safety lever on "FIRE".
- 7. Press trigger (hammer should go forward).

IX. CLEANING THE WEAPON.

1. Use rifle bore cleaner (RBC) to clean the face of the slide.
2. Clean the bore and chamber by:
 - a. Wetting a patch with RBC and running it back and forth through the bore several times.
 - b. Attach a bore brush to the cleaning rod and run it through the bore and chamber several times.
 - c. Run dry patches through the bore and chamber until they come out clean.
 - d. Inspect bore for fouling and residue. If it is not clean, repeat the above cleaning process.
3. Clean the other parts with RBC or a cleaning solvent to remove all grease, dirt, or powder fouling. Soak small parts in cleaning solution.
4. Dry the parts using clean, dry rags.
5. Cover all parts with a light coat of oil.